



For more efficiency and easy handling in the workplace!



Our high-performance lubricants for cutting and beveling to increase the tool life of saw blades (page 20)



Clamping shells or jaws for deformation- or corrosion-free clamping of tubes (page 19)



Quick-mounting base plates – ideal for frequent changes of location (page 21)



Pipe feeder for accurately feeding long and heavy pipes into GF and RA machines (page 22)

Our Mobile Workstation for the mobile site and/or workshop (page 23):

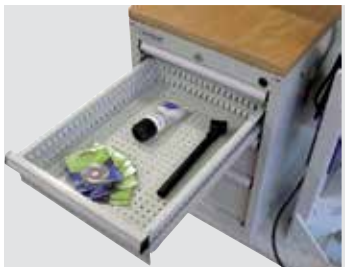

Lockable tool box with 4 drawers



Lifting table with height adjustment



Swarf collection tray



Roller pipe support

Accessories for GF and RA machines

Aluminum clamping shells

For RA 6, RA 8 and RA 12. Customized aluminum clamping shells for deformation-free clamping of thin-walled tubes.

When ordering, please indicate the outside diameter and/or inside diameter and the wall thickness of the tube to be worked on.

Comes with:

- 4 Cylinder head screws
- 1 Set of clamping shells

When ordering clamping shells for RA 8 you will also receive:

- 1 Drilling jig for the assembly of the clamping shells
- 2 Cylinder head screws for the drilling jig

Other dimensions are available.

Article	Version	Pipe OD [mm]	Pipe OD [inch]	Code	kg
Aluminum clamping shells	for RA 8	129.0	5.079	790 045 216	4.300
Aluminum clamping shells	for RA 8	139.1	5.476	790 045 219	4.700
Aluminum clamping shells	for RA 8	167.0	6.575	790 045 218	4.000
Aluminum clamping shells	for RA 8	168.3	6.626	790 045 220	3.600
Aluminum clamping shells	for RA 8	210.0	8.268	790 045 217	2.900
Aluminum clamping shells	for RA 12	204.0	8.030	790 047 222	–
Aluminum clamping shells	for RA 12	209.0	8.230	790 047 221	11.500
Aluminum clamping shells	for RA 12	219.0	8.620	790 047 220	11.200
Aluminum clamping shells	for RA 12	254.0	10.000	790 047 216	9.200
Aluminum clamping shells	for RA 12	273.0	10.750	790 047 219	8.400
Aluminum clamping shells	for RA 12	300.0	11.810	790 047 224	9.100
Aluminum clamping shells	for RA 12	324.0	12.760	790 047 218	5.800
Aluminum clamping shells	for RA 12	306.0	12.047	790 047 225	5.800

Clamping jaws

In pairs. Retrofit. While stock last.

Article	Code	kg
Special clamping jaws for RA 2 and RA 21 S	790 041 323	1.035
Aluminum clamping jaws for RA 4 and RA 41 Plus	790 046 250	2.600

Set of stainless steel clamping attachments

For GF 4 and GF 6 (AVM/MVM). For protection against contact erosion. Standard part of the GF 4 and the GF 6 (AVM/MVM).

Article	Version	Code	kg
Set of stainless steel clamping attachments for GF 4	right + left	790 142 241	0.310
Set of stainless steel clamping attachments for GF 6	right + left	790 143 200	0.510

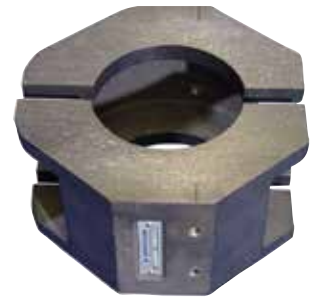

Aluminum clamping shells



Special clamping jaws for RA 2 and RA 21 S

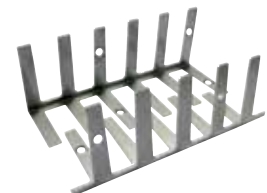

Set of stainless steel clamping attachments



GF TOP



GF LUB



Special gear oil

Continuous cooling system

On request for GF 4, GF 6, RA 8 and RA 12 available. For details, see page 13.

Saw blade lubricant GF TOP

Synthetic high-performance lubricant for cutting and beveling machines. Increases the tool life of the saw blade. Compliant with the food approval NSF H2. The screwable brush guarantees an easy and uniform application of lubricant on the saw blade.

Article	Version	Code	kg
Saw blade lubricant GF TOP	Tube, 180 g	790 060 228	0.205

Saw blade lubricant GF LUB

The NEW chlorine-free high-performance lubricant for cutting and beveling. Increases the tool life of the saw blade. This ecologically cutting compound is the environmentally friendly replacement for ROCOL: just with a new name and improved quality. GF LUB meets the latest environmental directives and ecological standards.

Article	Version	Code	kg
Saw blade lubricant GF LUB	Tube, 160 ml	790 041 016	0.160

Special gear oil

For all GF and RA machines.

Article	Version	Code	kg
Special gear oil	Bottle, 250 ml	790 041 030	0.235

Intermediate gearbox retrofit kit

To convert a standard pipe cutting and beveling RA machine (RA) to RA H (with intermediate gear) with the former FE 680 Motor (150 - 270 rpm). The intermediate gearbox reduces the cutting speed of the RA machine to 40 - 70 rpm and increases torque. For cutting high-performance materials e.g. Hastelloy® and Inconel. Fits all RA 2, RA 4, RA 41, RA 41 Plus, RA 6, RA 8 and RA 12 machines. The kit includes all parts necessary for retrofitting as well as additional gear oil.



Intermediate gearbox retrofit kit

Article	Code	kg
Intermediate gearbox retrofit kit	790 041 063	2.000

Swivel cable

To prevent twisting of the cable. For all GF, RA and PS machines with protection class II (double insulated).

Article	Version	Cable length [m/ft]	Code	kg
Swivel cable complete	230 V, 50/60 Hz EU	4/13.1	790 142 081	0.680
Swivel cable complete	120 V, 50/60 Hz US/CA	4/13.1	790 142 082	0.654
Swivel cable complete	230 V, 50/60 Hz CH	4/13.1	790 142 083	0.595
Swivel cable complete	230 V, 50/60 Hz AU	4/13.1	790 142 084	0.655
Swivel cable complete	120 V, 50/60 Hz GB	4/13.1	790 142 087	0.740
Swivel cable	230 V, 50/60 Hz EU	4/13.1	790 142 076	0.560
Swivel cable	120 V, 50/60 Hz US/CA	4/13.1	790 142 077	0.740
Swivel cable	230 V, 50/60 Hz CH	4/13.1	790 142 078	0.520
Swivel cable	120 V, 50/60 Hz GB	4/13.1	790 142 079	0.630
Swivel cable	230 V, 50/60 Hz AU	4/13.1	790 142 080	0.560



Swivel cable



Swivel cable complete

Quick-mounting base plates with integrated screw clamps

For quick mounting of the machine on work benches. Ideal for frequent changes of location.

Article	Code	kg
Quick-mounting base plate for GFX 3.0, RA 2, RA 21 S	790 041 027	4.230
Quick-mounting base plate for GF 4, GF 6, GFX 6.6, RA 4, RA 6, RA 8, RA 41 Plus	790 042 027	6.165
Quick-mounting base plate for PS 4.5 and PS 6.6	790 048 334	2.600



Quick-mounting base plates with integrated screw clamps

Pipe feeder base unit and extension unit

The pipe feeder accurately feeds long and heavy pipes into GF and RA machines. Very sturdy and stable design with powder-coated frames and stainless steel rollers.

Advantages:

- Extremely stable and sturdy
- Fast adjustment of dimensions
- Centerline of tubes and pipes adjust easily in seconds
- Steel frame coated for maintenancefree finish
- Rollers made of stainless steel
- Extension of the Pipe Feeder possible with Extension Unit
- Saves time and money
- No contamination
- Perfect for all kinds of steel

Base unit:

Fits all pipe cutting and beveling machines from Orbitalum Tools (except the RA 21 S and GF 20 AVM. RA 2, GFX 3.0, PS 4.5 and PS 6.6 on request). The machines can be directly mounted onto the base plate of the pipe feeder base unit, without further parts. The machines can be easily adjusted to the required cutting dimension using the hand-wheel-operated mechanical height adjustment. The machine is securely fastened to the base plate.



Pipe feeder base unit



Pipe feeder extension unit

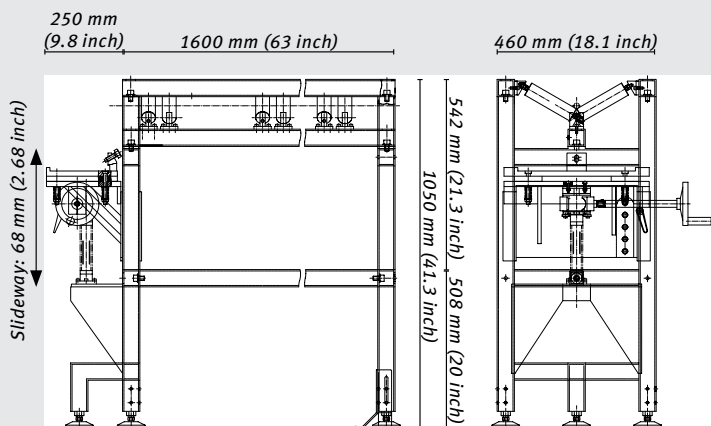

Extension unit:

To extend the base unit, can be used singularly or in multiples, easily bolted together.

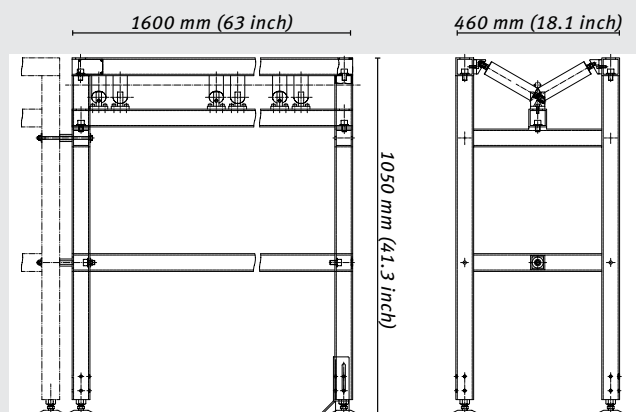

Floor bracket accessory:

To fasten the base unit or the extension unit to the floor.
The assembly consists of 4 brackets and 8 bolts with washers.

Application range/ Technical data	Pipe feeder base unit	Pipe feeder extension unit
Pipe OD	16 - 325 mm 0.63 - 12.8 inch	16 - 325 mm 0.63 - 12.8 inch
Dimensions approx.	185 x 105 x 50 cm 72.8 x 41.3 x 19.7 inch	approx. 160 x 105 x 50 62.9 x 41.3 x 19.7 inch
Load capacity max.	400 kg 881.8 lbs	400 kg 881.8 lbs
Height-adjustable mounting plate (adjusting range)	68 mm 2.68 inch	- -

Article	Code	kg
Pipe feeder base unit	790 068 051	116.000
Pipe feeder extension unit	790 068 061	72.000
Floor bracket accessory	790 068 0	1.900

Mobile Workstation

For the mobile site and/or workshop. The ideal addition for all Orbitalum pipe cutters (with exception of GF 20 AVM, RA 2, PS 4.5 and PS 6.6 on request).

- Safe and easy transportation of machines and equipment on site
- Flexible operation at each working station
- Elimination of material handling and setting up of the machines e.g. no requirement to mount the machines to benches
- Height-adjustable pipe support with stainless steel roller
- The tool box comes with 4 drawers for tools and equipment and is lockable
- Lifting table with height adjustment of the GF- and RA-machines to the required pipe dimension
- Accurate and clean work by swarf collection tray

Technical data	Mobile Workstation
Dimensions (hxlxw)	91 x 115 x 43 cm 35.8 x 45.3 x 16.9 inch
Load capacity max.	675 kg 1488.1 lbs

Article	Code	kg
Mobile Workstation	790 068 071	137.000



Mobile Workstation