



ORBIWELD TP - unique design and functionality!



## Open Orbital Weld Heads

41

# Overview of open orbital weld heads ORBIWELD TP

## Open orbital weld heads ORBIWELD TP / ORBIWELD TP AVC/OSC

Model		TP 250	TP 400	TP 400 KD3-100	TP 600	TP 600 AVC/OSC	TP 1000	TP 1000 AVC/OSC
Code		811 000 001	812 000 001	812 000 003	813 000 001	813 000 002	814 000 001	814 000 002
Application range	[mm]	20 - 77	30 - 115	30 - 115	70 - 170	70 - 170	120 - 275	120 - 275
	[inch]	1/2 - 3	1 1/2 - 4 1/2	1 1/2 - 4 1/2	3 - 6	3 - 6	5 - 10	5 - 10
Dimension „A“: excluding cold wire	[mm]	86,0	108,0	108,0	146,0	-	216,0	-
	[inch]	3.386	4.252	4.252	5.748	-	8.504	-
Dimension „B“: with cold wire KD 3-62	[mm]	x	155,0	180,0	176,0	-	216,0	-
	[inch]	x	6.102	7.087	6.929	-	8.504	-
Dimension „C“: with cold wire KD 3-100	[mm]	x	x	177,0	196,0	215,0	237,0	274,0
	[inch]	x	x	6.969	7.717	8.465	9.331	10.787
Dimension "D"	[mm]	85,0	120,0	182,0	140,0	186,0	170,0	206,0
	[inch]	3.346	4.724	7.165	4.724	7.323	6.299	8.110
Dimension "E": electrode	[mm]	74,0	90,0	162,0	97,0	172,0	146,0	191,0
	[inch]	2.913	3.543	6.378	3.819	6.772	5.748	7.520
Dimension "F"	[mm]	125,0	200,0	200,0	202,0	202,0	270,0	270,0
	[inch]	4.921	7.874	7.874	7.953	7.953	10.630	10.630
Weight excluding cold wire feed and hose package	[kg]	2,1	5,4	-	8,0	-	16,9	-
	[lbs]	4.630	11.905	-	17.637	-	37.258	-
Weight including cold wire feed and excluding hose package	[kg]	-	-	-	-	10,4	-	22,0
	[lbs]	-	-	-	-	22.928	-	48,500

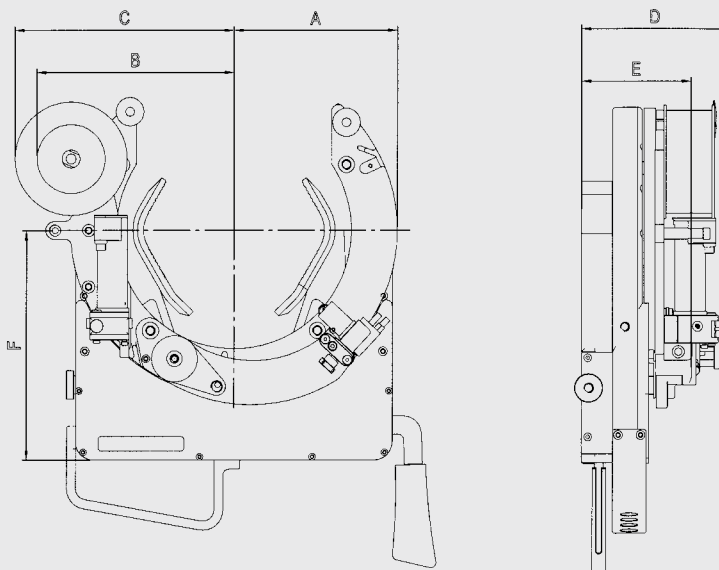

## Electrode lengths for TP weld heads

Model		TP 250	TP 400	TP 400 AVC/OSC	TP 600	TP 600 AVC/OSC	TP 1000	TP 1000 AVC/OSC
Code		811 000 001	812 000 001	812 000 002	813 000 001	813 000 001	814 000 001	814 000 002
Length	[mm]	18 - 32	30 - 55	30 - 55	30 - 55	30 - 55	30 - 55	30 - 55
	[inch]	0.709 - 1.260	1.181 - 2.165	1.181 - 2.165	1.181 - 2.165	1.181 - 2.165	1.181 - 2.165	1.181 - 2.165

# Open orbital weld heads ORBIWELD TP

## Open orbital weld heads ORBIWELD TP 250-1000

The ORBIWELD TP series has a unique design and functionality. An extremely compact design has been achieved thanks to the drive motor that is fully integrated into the housing. The completely new drive concept has made the well-known large and costly drives associated with conventional weld heads unnecessary.

### Features:

- Can be used with and without cold wire attachment, as the cold wire feed nozzle can be adjusted exactly in both a vertical and horizontal direction via an adjustment unit.
- Open arc system.
- The arc length is kept at a constant gap mechanically.
- Infinitely variable clamping mechanism.
- The water-cooled TIG Torch head can be swiveled in any direction and allows fillet welds or short hollowed out tubes to be welded. In the models TP 400, 600, and 1000 the TIG Torch head is secured to a slide unit that allows the position of the electrodes to be finely adjusted with great accuracy even during welding.
- With a simple to operate control knob, it is possible to adjust the clamping area across the weld head's entire nominal range.
- The ORBIWELD TP weld heads with clamping shells made from tool steel ensures optimum retention to the tube's surface (very good grip properties).
- The weld heads are easily centered to the tube and are clamped in place with the help of a tension lever. No additional remote control is required thanks to the keys integrated directly into the weld head housing.
- The standard hose package length is 7.5 m (24.6 ft). Extensions are possible. See on page 40.

**Please note that the weld head needs for operation an earth cable as well as a control cable that must be ordered separately.**



ORBIWELD TP 600  
with KD 3-100 cold wire feed



ORBIWELD TP 250  
with external cold wire feed KD 4



ORBIWELD TP 400  
with KD 3-62 cold wire feed



ORBIWELD TP 400  
with KD 3-100 cold wire feed

## ORBIWELD TP 250 - 100 without cold wire unit

Article	Tube OD [mm]	Tube OD [inch]	Code	Weight weld head [kg]	Dispatch weight [kg]
Open weld head TP 250*	22,00 - 77,00	1/2 - 3	811 000 001	10,500	18,000
Open weld head TP 400*	30,00 - 115,00	1 1/2 - 4 1/2	812 000 001	12,500	20,000
Open weld head TP 600*	70,00 - 170,00	3 - 6	813 000 001	13,800	21,350
Open weld head TP 1000*	120,00 - 275,00	5 - 10	814 000 001	19,000	36,500

\* Without cold wire unit (for retrofit see following page).

## ORBIWELD TP 250 - 1000 with cold wire unit

Article	Tube OD [mm]	Tube OD [inch]	Code	Gewicht Schweißzange [kg]	Versandgewicht [kg]
Open weld head TP 250 with KD 4	22,00 - 77,00	1/2 - 3	811 000 005	12,500	20,000
Open weld head TP 400 with KD 3-62	30,00 - 115,00	1 1/2 - 4 1/2	812 000 005	-	-
Open weld head TP 400 with KD 3-100	30,00 - 115,00	1 1/2 - 4 1/2	812 000 006	-	-
Open weld head TP 600 with KD 3-100	70,00 - 170,00	3 - 6	813 000 005	-	-
Open weld head TP 1000 with KD 3-100	120,00 - 275,00	5 - 10	814 000 005	-	-

# Open Orbital Weld Heads

## Cold wire feeds for TP heads for retrofit

### Cold wire feed KD 4 for ORBIWELD TP 250

Cannot be used for ORBIWELD TP 400/600/1000.

Consisting of:

- Axis drive motor.
- Adjustable wire feed tips.
- Wire reel retainer for D 100 mm/1kg (3.937 inch) standard reels.
- External cold wire box.



KD 4 with open lift-off lid

Article	Code	kg
Cold wire feed KD 4 for ORBIWELD TP 250	811 050 001	2,000

### Cold wire feed KD 3-62 and KD 3-100 for ORBIWELD TP 400

Can be assembled directly on the weld head, also making pulse synchronous wire feed possible.

Consisting of:

- Axis drive motor.
- Adjustable wire feed tip.
- Wire reel retainer with D 62 mm/1 kg (2.440 inch) special wire reel (empty reel) with D 100 mm/1 kg (3.937 inch) standard reel

Article	Code	kg
Cold wire feed KD 3-62 for ORBIWELD TP 400 including empty reel	812 050 001	5,500
Additional empty reel for KD 3-62	812 018 019	0,038
Cold wire feed KD 3-100 for ORBIWELD TP 400*	812 050 061	-

\*For the retrofit the weld head has to be sent to the Orbitalum service department.

### Cold wire feed KD 3-100 for ORBIWELD TP 600

Can be assembled directly on the weld head, also making pulse synchronous wire feed possible.

Consisting of:

- Axis drive motor.
- Adjustable wire feed tip.
- Wire reel retainer for D 100/1kg (3.937 inch) standard wire reels.

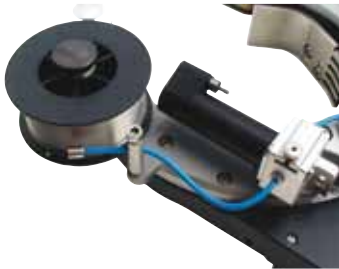

KD 3-100 with D 100 standard wire reels

Article	Code	kg
Cold wire feed KD 3-100 for ORBIWELD TP 600	813 050 001	0,680

### Cold wire feed KD 3-100 for ORBIWELD TP 1000

Can be assembled directly on the weld head, also making pulse synchronous wire feed possible.

Consisting of:

- Axis drive motor.
- Adjustable wire feed tip.
- Wire reel retainer for D 100 mm/1kg (3.937 inch) standard wire reels.

Article	Code	kg
Cold wire feed KD 3-100 for ORBIWELD TP 1000	814 050 008	0,720

# Open orbital weld heads ORBIWELD TP AVC/OSC

## Open orbital weld heads ORBIWELD TP AVC/OSC with oscillation OSC and arc voltage control AVC

Can be used for thick wall tubes (multiple layer welds).

As ORBIWELD TP (see p. 43). The weld heads of the ORBIWELD TP AVC/OSC series are also provided with a motorized travel option for the TIG Torch across the nominal diameter, so that no additional mechanical basic presetting is required for any change in the tube diameter.

Additional properties of the tube-to-tube weld heads ORBIWELD TP AVC/OSC with oscillation OSC and arc voltage control AVC:

- The oscillation width is 20 mm (0.787 inch).
- Cold feed wire feed unit with mount for D 100/1kg (3.937 Inch) wire reels fitted directly on the weld head.
- With a simple to operate control knob, it is possible to adjust the clamping area across the weld head's entire nominal range.

**Please note that the weld head needs for operation an earth cable as well as a control cable that must be ordered separately.**



ORBIWELD TP 400 AVC/OSC

Article	Tube OD [mm]	Tube OD [inch]	Code	Weight weld head [kg]	Dispatch weight [kg]
Open weld head TP 400 AVC/OSC*	30,00 - 115,00	1 ½ - 4 ½	812 000 002	12,700	24,800
Open weld head TP 600 AVC/OSC*	70,00 - 170,00	3 - 6	813 000 002	15,500	33,300
Open weld head TP 1000 AVC/OSC*	120,00 - 275,00	5 - 10	814 000 002	27,500	45,300

\* Only usable with an ORBIMAT CA AVC/OSC orbital welding power supply. See page 10.

## Other accessories for open orbital weld heads



Expansion clamping shell set for ORBIWELD TP 250



Clamping shell set for ORBIWELD TP 250



Additional clamping stainless steel shell sets for ORBIWELD TP



Control cable



Earth cable

### Expansion clamping shell set for ORBIWELD TP 250

To extend the clamping area up to a minimum diameter of Ø 12 mm (0.472 inch).

Article	Version	Tube OD [mm]	Tube OD [inch]	Code	kg
Expansion clamping shell set for TP 250 (4pcs.)	Stainless steel	12,00 - 45,00	0.472 - 1.772	811 050 002	0,096
Expansion clamping shell set for TP 250 (4pcs.)	Hardened steel	12,00 - 45,00	0.472 - 1.772	811 050 009	0,023
Clamping shell set for TP 250* (2pcs.)	-	12,00 - 22,00	0.472 - 0.866	811 002 001	0,030

\* Please indicate requested tube OD when ordering.

### Additional stainless steel clamping sheet set for ORBIWELD TP

The TP series are made from hardened tool steel as standard. For applications in stainless steel we recommend the following additional clamping shell sets made from stainless steel:

Article	Code	kg
Additional clamping shell set for TP 250 (4pcs.)	811 050 006	0,069
Additional clamping shell set for TP 400 (4pcs.)	812 050 002	0,100
Additional clamping shell set for TP 600 (4pcs.)	813 050 002	0,150
Additional clamping shell set for TP 1000 (4pcs.)	814 050 001	0,071

### Control cable

Suitable for all ORBIWELD TP heads.

Article	Length [m]	Length [ft]	Code	kg
Control cable for all ORBIWELD TP heads	7,5	24.6	811 050 003	1,202

### Earth cable

Article	Length [m]	Length [ft]	Code	kg
Earth cable for power supplies with 165 ampere	5,0	16.4	811 050 004	2,351
Earth cable for power supplies with 300 ampere	5,0	16.4	811 050 005	2,400
Earth cable for 300 AVC/OSC power supplies	5,0	16.4	812 050 046	2,850

## Consumables for ORBIWELD TP heads

### Clamp sleeves for ORBIWELD TP

Article	Code		kg
Clamp sleeve TP 250	811 020 018		-
Clamp sleeve TP 400/600/1000	812 020 024		-



*Clamp sleeves*

### Plunger for clamp sleeves for ORBIWELD TP

Article	Code		kg
Plunger for clamp sleeve TP	812 005 002		-



*Plunger for clamp sleeve*

### Torch isolators for ORBIWELD TP

Article	Code		kg
Torch isolator TP 250	811 013 001		-
Torch isolator TP 400/600/1000	812 005 001		-



*isolator seals and torch seals*

### Wire cores for ORBIWELD TP

Article	Code		kg
Wire core TP 250 L3,5m d0,8mm	811 020 030		-
Wire core TP 400/600/1000 L1m d0,8mm	812 020 041		-

### HF spiral zu ORBIWELD TP

Article	Code		kg
HF spiral TP	831 001 027		-



*HF spiral*

### Torch seals for ORBIWELD TP 250

Article	Code		kg
Torch seal TP 250	811 005 020		-



*Wire cores*

# Open Orbital Weld Heads